

KRAL Pumps with Magnetic Coupling.

KRAL



KRAL pumps with magnetic coupling are hermetically sealed and can handle temperatures to 250 °C.



Operation, materials and accessories.

Max. flow rates:	2.900 l/min.
Max. pressure:	100 bar.
Temperature range:	-40 °C to 250 °C.
Casing:	Nodular cast iron, silafont and steel.
Spindles:	Nitrated steel.
Energy density:	250 kJ/m ³ .
Magnet material:	Sm ₂ Co ₁₇ – Permanent magnets.

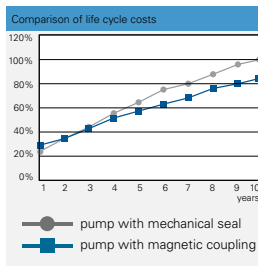

Leakage-free and clean.

Critical fluids containing substances endangering the health or the environment should not leak to the atmosphere.

Conventional shaft seals are lubricated by the fluid. A leakage flow is specified and necessary for proper operation.

Magnetic couplings replace conventional shaft seals. KRAL pumps with magnetic coupling are hermetically sealed, the environment remains clean.

Can be used to 250 °C.

Thermal distortion and the temperature limits of elastomeric sealing elements restrict the use of screw pumps in high temperature applications.



If temperatures up to 250 °C are handled, KRAL pumps with magnetic coupling are the right choice.

Reduced life cycle costs.

Spare parts and maintenance costs of mechanical seals increase life cycle costs.

The use of high quality mechanical seals in KRAL screw pumps is the standard. Even when properly applied, mechanical seals are subject to wear. Spare parts and maintenance costs arise.

KRAL magnetic couplings are maintenance free, due to the lack of a mechanical seal and increased life of the ball bearing. The cost premium of a pump with a magnetic coupling will be typically amortized after only three years of operation.

Protection of delivery medium.

With conventional seals, oxygen from the atmosphere may diffuse through the sealing gap into the fluid. When the fluid crystallizes from contact with oxygen, the process is interrupted and expensive plant shut downs can result.

KRAL pumps with magnetic coupling are hermetically sealed and protect the integrity of the fluid.



Low price.

A magnetic coupling is required to transmit high torques. This can make the magnetic coupling large and expensive.

For high torque transmission, strong magnets are necessary.

The new generation of KRAL pumps are cost optimized and designed to the requirements of the magnetic coupling. For many years, KRAL has successfully manufactured magnetic coupled pumps. Experiences and actual field tested applications were incorporated in the design.



Overload protection.

If the operating limits are exceeded, the pump may become damaged.

Solids in the fluid can lead to blockade and damage the spindle and the housing. In most cases the final manufactured product is not to specification, and the pump must be replaced. If the decoupling is controlled, and the pump stops, the pump and magnetic coupling will suffer no damage.

The magnetic coupling can prevent consequential damage.



Areas of application.

KRAL pumps with magnetic couplings are screw pumps for pumping fuels, oils and other non aggressive liquids. They are used primarily in industrial applications, such as:

- Marine, as circulation pumps for fuels.
- Plastics processing, especially polyurethane applications.
- Power plant engineering, as circulation pumps for fuels.
- Plant engineering and the chemical industry for heat transfer fluids.

Innovative Solutions for Increased Safety

Low price.

For many years KRAL has been successfully manufacturing magnetic couplings with high strength $\text{Sm}_2\text{Co}_{17}$ permanent magnets. The maximum energy density of approx.

250 kJ/m^3 is five times greater than standard Al-NiCo magnets. The magnetic coupling as a result is very compact.

Long life bearing.

Because the magnetic coupling is sealed, the fluid does not come into contact with the atmosphere. The fluid cannot react with the oxygen in the air to form residues that can damage the ball bearing. As a result the bearing has a long life.

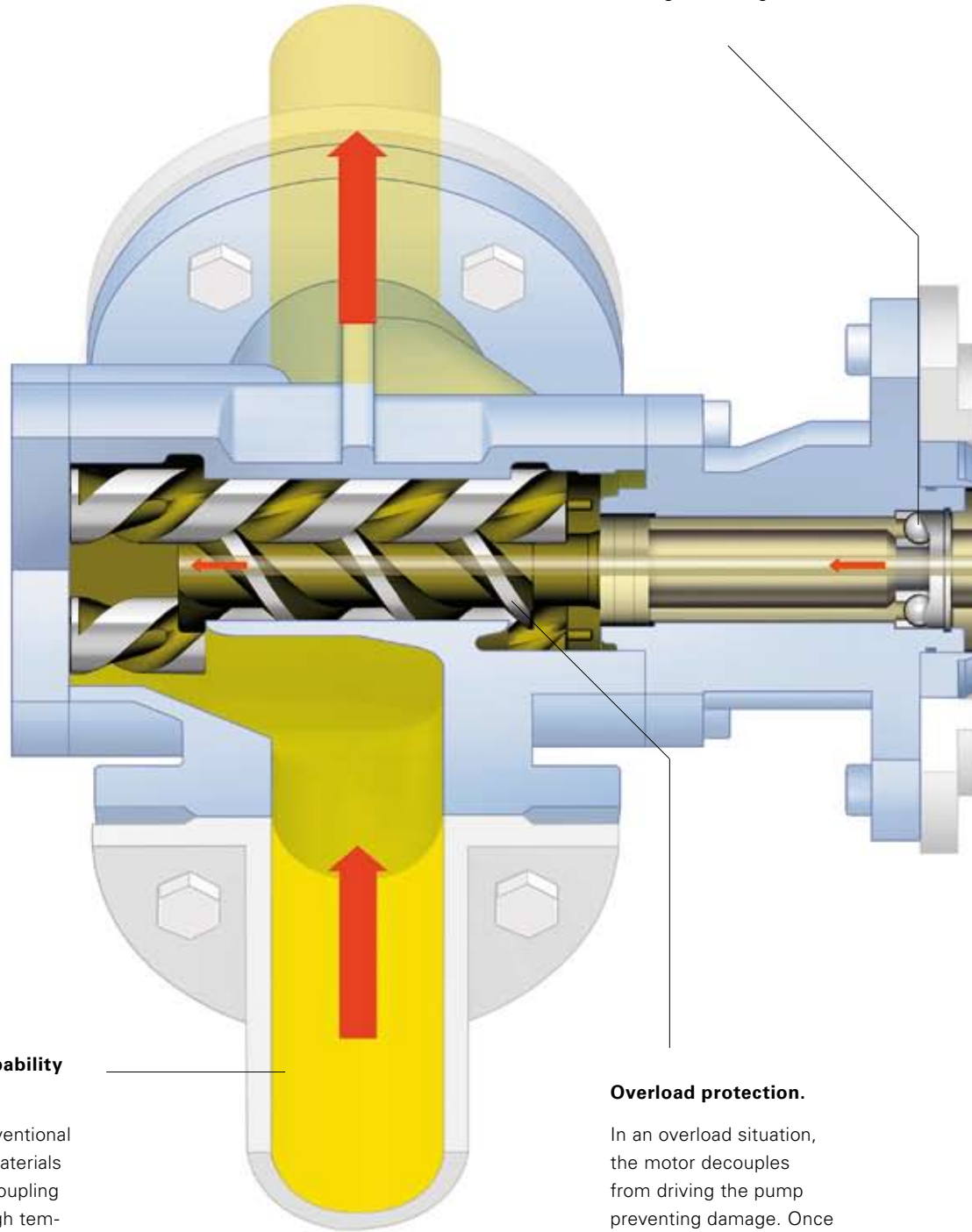

Temperature capability to 250 °C.

Compared to conventional shaft seals, the materials of the magnetic coupling have far better high temperature capability. Hot fluids can be pumped without risk.

Overload protection.

In an overload situation, the motor decouples from driving the pump preventing damage. Once the motor is fully stopped the magnetic coupling will synchronize and the pump can be restarted. This safety feature avoids damage to the pump.

Function.

The rotation of the electric motor is transferred through the magnetic coupling to the pump spindles without contact. The electric motor and the pump shaft each have a rotor with several magnets. During operation, the two rotors run in synchronized rotation.

Hermetically sealed.

The containment can is the sealing element of the KRAL pump. It encapsulates the pump shaft and inner magnet hub. If, in the illustration, you cover the outer rotor on the shaft of the electric motor, the fully encapsulated nature of the pump becomes apparent.

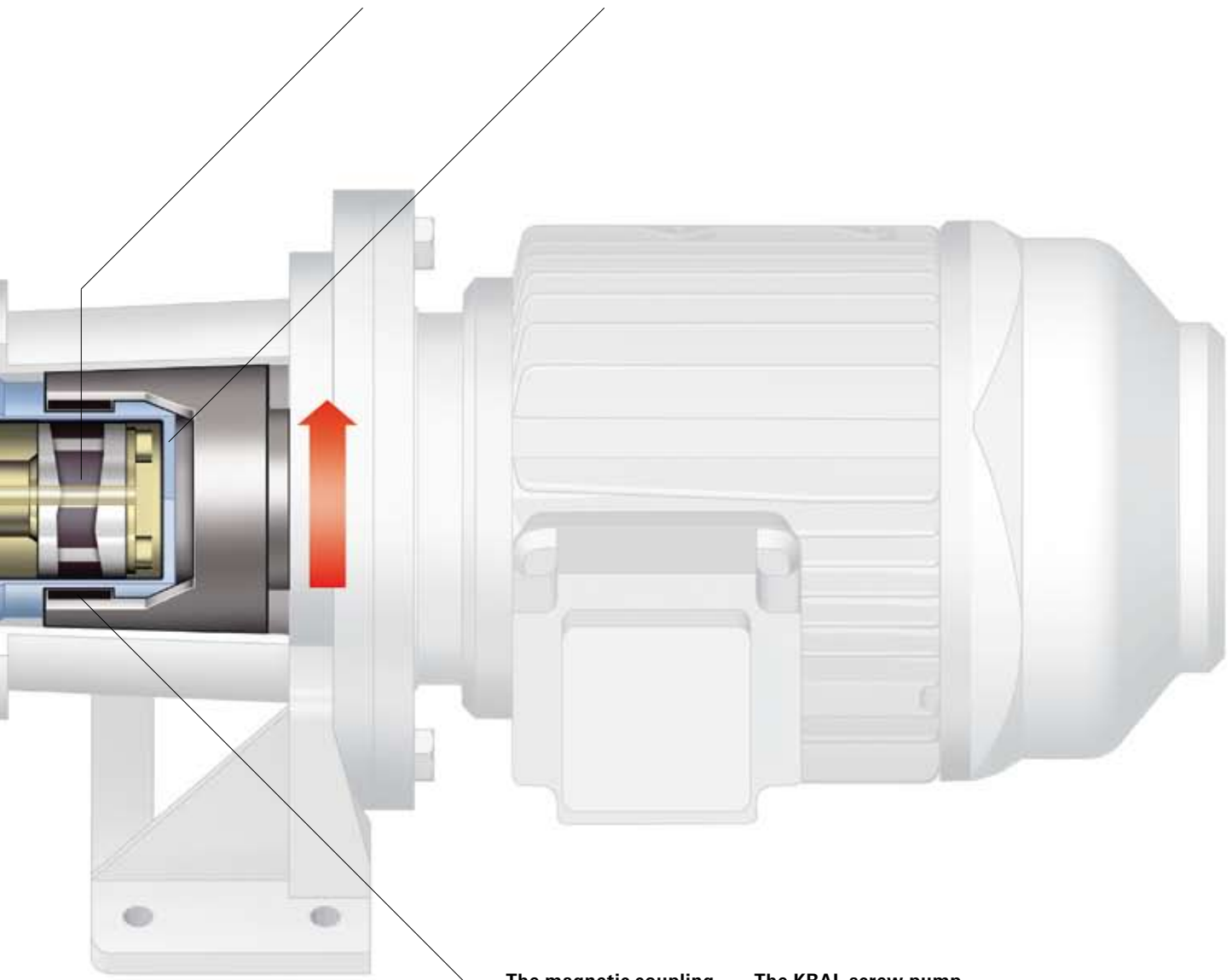

The magnetic coupling has no wear.

The magnetic coupling is a contact free component. The pump spindles are driven without contact by the magnets on the outer and inner rotor. As there is no friction, there is no wear.

The KRAL screw pump advantages.

Compared to other types of pump, KRAL screw spindle pumps provide high flow rates in restricted spaces. Delivery is low in pulsation and quiet.

Technical Data, Dimensions and Weights

Technical data, Dimensions and Weights apply for the Series K. For higher pressures of up to 100 bar and flow rates up to 2.900 l/min, please provide application information for the Series M and C.

Technical data.		5-20	32-42	55-118	160-275	370-450	550-660	**
Q_{th} (1.450 min ⁻¹ , 0 bar) l/min		5-21	5-43	59-119	166-282	368-448	543-668	
Pressure	bar	16	16	16	16	16	16	
Temperature	°C	250	250	250	250	250	250	
Viscosity*	mm ² /s							
min.		2	2	2	2	2	2	
max.		100.000	100.000	100.000	100.000	100.000	100.000	
Speed*	min ⁻¹							
50 Hz		2.900	2.900	2.900	2.900	2.900	1.450	
60 Hz up to		3.500	3.500	3.500	3.500	3.500	1.750	
Inlet pressure	bar	16	16	16	16	16	16	

*Please ask for other data.

**Larger sizes available upon request.

Dimensions / Weights.	DNd	DNs	g	L5	LP	kg
K 5-20	25	25	150	201	251	7
K 32-42	32	32	169	244	297	11
K 55-118	50	50	220	290	349	18
K 160-275	80	80	250	364	418	33
K 370-450	100	100	270	396	453	43
K 550-660	100	125	360	561	628	78

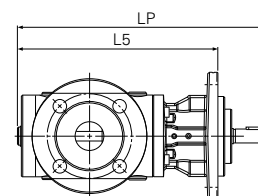
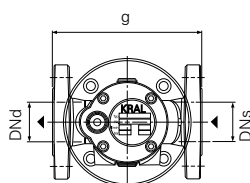

Practical examples.

More safety for the Marine.



Medium:
Heavy fuel oil (HFO).
Delivery rate: 50 l/min.
Pressure: Up to 8 bar.
Temperature: Up to 190 °C.
Viscosity: 3 to 760 mm²/s.

Diesel engines are used on board of offshore ships as the power plant and auxiliary engine. KRAL pumps deliver the fuel in the booster module, in this example heavy fuel oil.

Our customer, a large European ship owner with global establishments including the USA, has upgraded with KRAL. For this upgrade pumps with mechanical seals have been changed to KRAL pumps with magnetic coupling. The reason for this upgrade was, to avoid the normal leakage of a mechanical seal. The leakage evident from lubricating the sealing faces can be a high fire risk. A magnetic coupling is hermetically sealed and leakage free.

High viscosity polyurethanes.



Photo material by Krauss-Maffei Kunststofftechnik GmbH.

Medium:
Polyol and isocyanate.
Delivery rate: 20 to 110 l/min.
Pressure: Up to 15 bar.
Temperature: Up to 190 °C.
Viscosity:
300 to 5.000 mm²/s.

Polyurethane is obtained when polyol and isocyanate is mixed, polyurethane is used in a wide variety of products including seat cushions and instrument panels.

KRAL Pumps with magnetic couplings are hermetically sealed, this prevents the forming of carbamide crystals in PUR-machines. The carbamide crystals may block the foaming facility's mixer casing and incorrect mixing formulation causes a faulty end product.

Hot fluids.

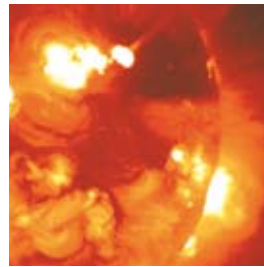

Medium: Pitch.
Delivery rate: 120 l/min.
Pressure: 8 bar.
Temperature: 110 to 220 °C.
Viscosity:
200 to 2.000 mm²/s.

For the manufacture of graphite components, pitch is used. Trucks deliver the bitumen heated, this allows the bitumen to be pumped or transferred. With screw pumps this pitch will be transferred out of the stock tank into a day tank. Due to the high temperature and sticky nature it can develop problems for standard seals.

To eliminate this problem, a well known graphite manufacturer is using KRAL screw pumps with magnetic coupling and heated jacketing.

More examples for hot fluids are heat transfer oils and hot waxes.

Joint projects.



Our business partners are particularly appreciative of the cooperative collaboration with KRAL. From the best possible support to the successful conclusion of the project, friendly business relations are always the order of the day. We take the time to talk to our customers and collaborate closely with them on technical matters. You can rely on KRAL.



KRAL